

AX-EM-0016DN Digital Output Module User Manual

Thank you for choosing AX series programmable controller (programmable controller for short).

AX-EM-0016DN digital output module (DO module for short) is a sink output module that provides 16 digital outputs, working with the main module of the programmable controller.

The manual mainly describes the specifications, features, wiring, and use methods. To ensure that you use the product safely and properly and bring it into full play, read the manual carefully before the installing. For details about the user program development environments and user program design methods, see *AX Series Programmable Controller Hardware User Manual* and *AX Series Programmable Controller Software User Manual* that we issue.

The manual is subject to change without prior notice. Please visit <http://www.invt.com> to download the latest manual version.

1 Safety precautions

1.1 Warning

Symbol	Name	Description	Abbreviation
	Danger	Severe personal injury or even death can result if related requirements are not followed.	
	Warning	Personal injury or equipment damage can result if related requirements are not followed.	

1.2 Delivery and installation

	◇ Only trained and qualified professionals are allowed to perform installation, wiring, maintenance, and inspection.
	◇ Do not install the programmable controller on inflammables. In addition, prevent the programmable controller from contacting or adhering to inflammables.
	◇ Install the programmable controller in a lockable control cabinet of at least IP20, which prevents the personnel without electrical equipment related knowledge from touching by mistake, since the mistake may result in equipment damage or electric shock. Only personnel who have received related electrical knowledge and equipment operation training can operate the control cabinet.
	◇ Do not run the programmable controller if it is damaged or incomplete.
	◇ Do not contact the programmable controller with damp objects or body parts. Otherwise, electric shock may result.

1.3 Wiring

	◇ Only trained and qualified professionals are allowed to perform installation, wiring, maintenance, and inspection.
	◇ Fully understand the interface types, specifications, and related requirements before wiring. Otherwise, incorrect wiring will cause abnormal running.
	◇ Cut off all power supplies connected to the programmable controller before performing wiring.
	◇ Before power-on for running, ensure that each module terminal cover is properly installed in place after the installation and wiring are completed. This prevents a live terminal from being touched. Otherwise, physical injury, equipment fault or misoperation may result.
	◇ Install proper protection components or devices when using external power supplies for the programmable controller. This prevents the programmable controller from being damaged due to external power supply faults, overvoltage, overcurrent, or other exceptions.

1.4 Commissioning and running

	◇ Before power-on for running, ensure that the working environment of the programmable controller meets the requirements, the wiring is correct, the input power specifications meet the requirements, and a protection circuit has been designed to protect the programmable controller so that the programmable controller can run safely even if an external device fault occurs.
	◇ For modules or terminals requiring external power supply, configure external safety devices such as fuses or circuit breakers to prevent damage caused due to external power supply or device faults.

1.5 Maintenance and component replacement

	◇ Only trained and qualified professionals are allowed to perform maintenance, inspection, and component replacement for the programmable controller.
	◇ Cut off all power supplies connected to the programmable controller before terminal wiring.
	◇ During maintenance and component replacement, take measures to prevent screws, cables and other conductive matters from falling into the internal of the programmable controller.

1.6 Disposal

	◇ The programmable controller contains heavy metals. Dispose of a scrap programmable controller as industrial waste.
	◇ Dispose of a scrap product separately at an appropriate collection point but not place it in the normal waste stream.

2 Product introduction

2.1 Model and nameplate

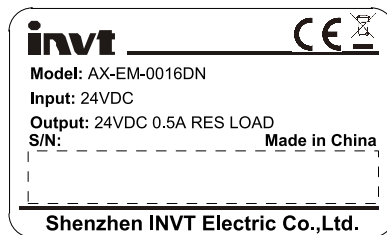

Figure 2-1 Product nameplate

AX-EM-00 16 DN

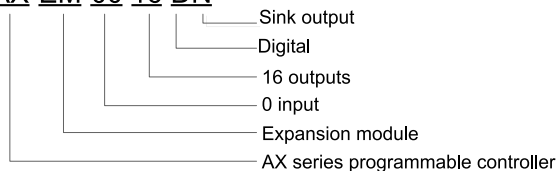

Figure 2-2 Product model

2.2 Function overview

The DO module is one of the expansion modules of the programmable controller main module.

As a sink transistor output module, the DO module has 16 digital output channels, with the max. current on the common terminal up to 2 A, and provides the short-circuit protection function that limits the max. current to 1.6A.

2.3 Structural dimensions

The structural dimensions (unit: mm) of the DO module are shown in the following figure.

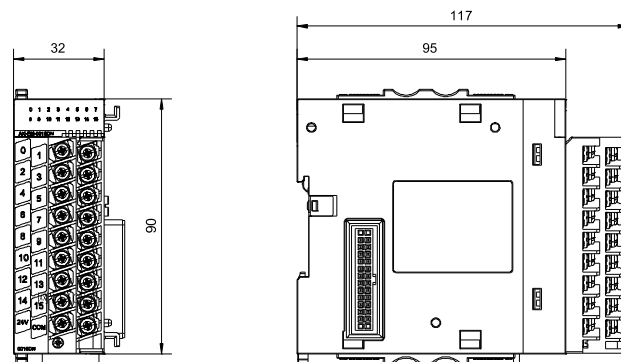
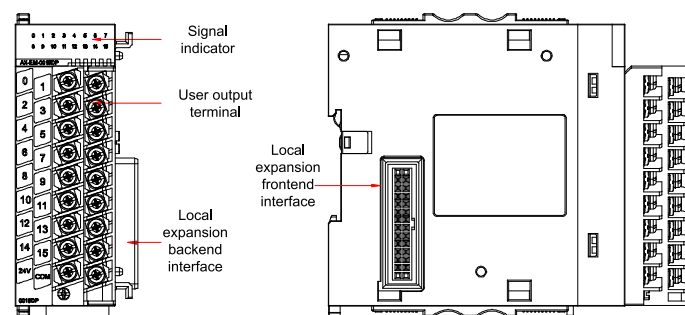

Figure 2-3 Structural dimensions

3 Interface

3.1 Interface distribution



Interface	Description
Signal indicator	Each corresponds to a channel of output signal. An indicator is on when the output is valid, and it is off when the output is invalid.
User output terminal	16 outputs
Local expansion frontend interface	Connects to frontend modules, disallowing hot swapping.
Local expansion backend interface	Connects to backend modules, disallowing hot swapping.

3.2 Terminal definition

Terminal No.	Type	Function
0	Output	Digital output port 0
1	Output	Digital output port 1
2	Output	Digital output port 2

Terminal No.	Type	Function
3	Output	Digital output port 3
4	Output	Digital output port 4
5	Output	Digital output port 5
6	Output	Digital output port 6
7	Output	Digital output port 7
8	Output	Digital output port 8
9	Output	Digital output port 9
10	Output	Digital output port 10
11	Output	Digital output port 11
12	Output	Digital output port 12
13	Output	Digital output port 13
14	Output	Digital output port 14
15	Output	Digital output port 15
24V	Power input	24V DC power supply
COM	Common terminal of power supply	Common terminal

4 Installation and wiring

Using modular design, the programmable controller is easy to install and maintain. As for the DO module, the main connection objects are the CPU module, EtherCAT module, and expansion modules.

The modules are connected by using the module-provided connection interfaces and snap-fits.

4.1 4.1 Installation procedure

Step 1 Slide the snap-fit on the DO module in the direction shown in following figure.

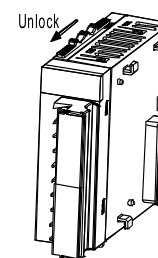

Step 2 Align with the connector on the CPU module for interlocking.

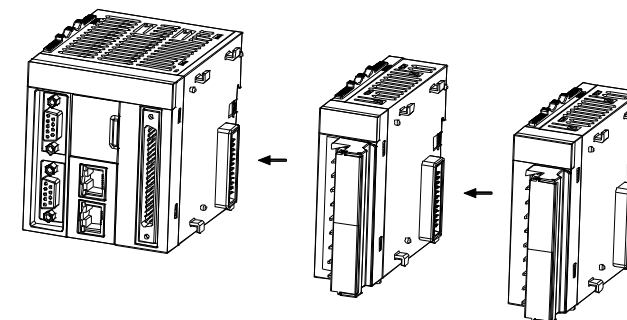

Step 3 Slide the snap-fit in the direction shown in the following figure to connect and lock the two modules.

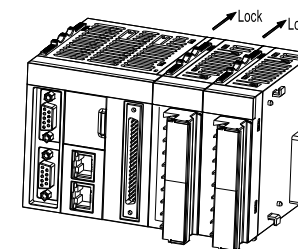

Step 4 As for standard DIN rail installation, hook the respective module into the standard installation rail until the snap-fit clicks into place.

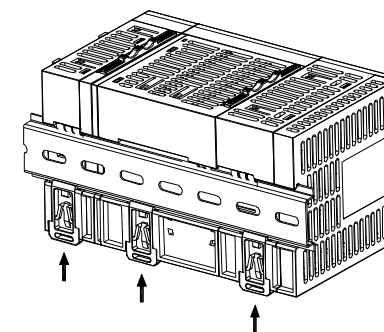

4.2 Wiring

The user terminal wiring is shown in the following figure.

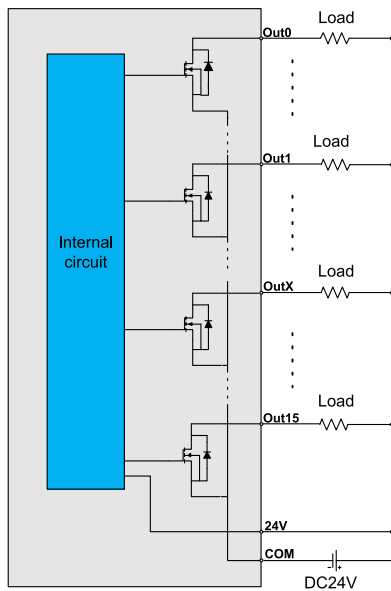

Figure 4-1 Terminal wiring

Note:

- The DO module needs to be externally powered for normal working. For details, see 5.1 Power parameters.
- The module needs to be installed on a properly-grounded metal bracket, and the metal dome at the module bottom must be in good contact with the bracket.
- Do not bind the sensor cable together with the AC cable, main circuit cable, or high-voltage cable. Otherwise, the binding can increase noise, surge, and induction impact. When using shielded cables, use single-point grounding for the shield layer.
- When the product uses inductive load, it is recommended to connect freewheeling diodes in parallel with the load to release the back EMF generated when the inductive load is disconnected, preventing damage to the device or the load.

5 Technical parameters

5.1 Power parameters

Parameter	Range
Power supply voltage	Internally powered, 5VDC (-10% – +10%)
External 24V voltage	24VDC (-15% – +5%)

5.2 Performance parameters

Parameter	Specifications
Output channel	16
Output connection method	18-point wiring terminals
Output type	Sink output
Power supply voltage	24VDC (-15% – +5%)
Output voltage class	12V–24V (-15% – +5%)
ON response time	< 0.5ms
OFF response time	< 0.5ms
Max. load	0.5A/point; 2A/common terminal (resistive load)
Isolation method	Magnetic
Output action display	The output indicator is on.
Short-circuit protection output	Max. current limited to 1.6A when protection is enabled

6 Application instance

The following assumes that the first channel of the DO module outputs valid conductivity and AX70-C-1608P is the main module of the programmable controller.

Step 1 Create a project. Add the device description file (AX_EM_0016DN_1.1.1.0.devdesc.xml) corresponding to the DO module to the project. See the following figure.

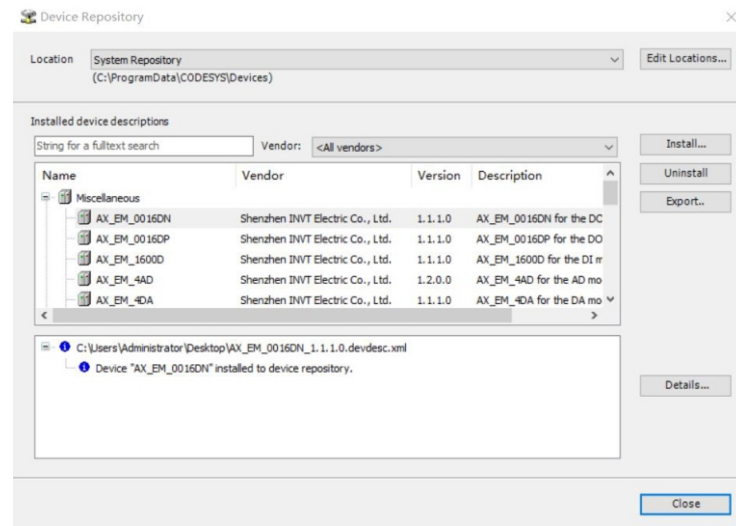

Step 2 Use the ST programming language to program the DO module, define the mapping variables Q1_0 and Q2_0, and set the channels corresponding to the variables to valid conductive. See the following figure.

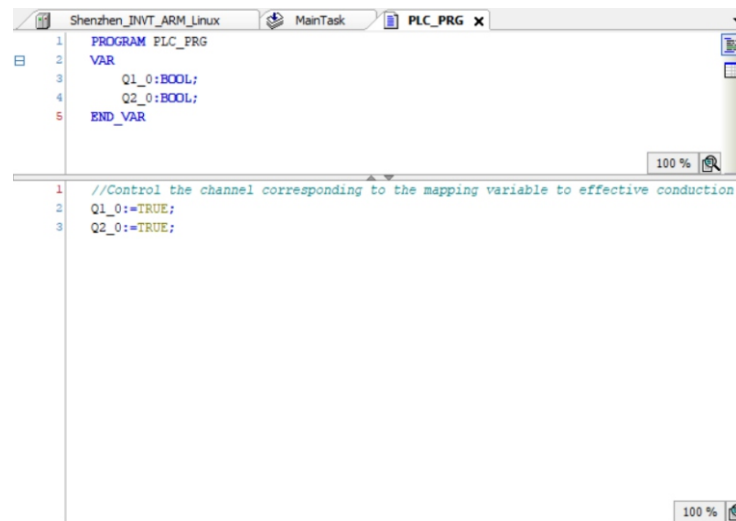

Step 3 Map the variables Q1_0 and Q2_0 defined in the program to the first channel of the DO module. See the following figure.

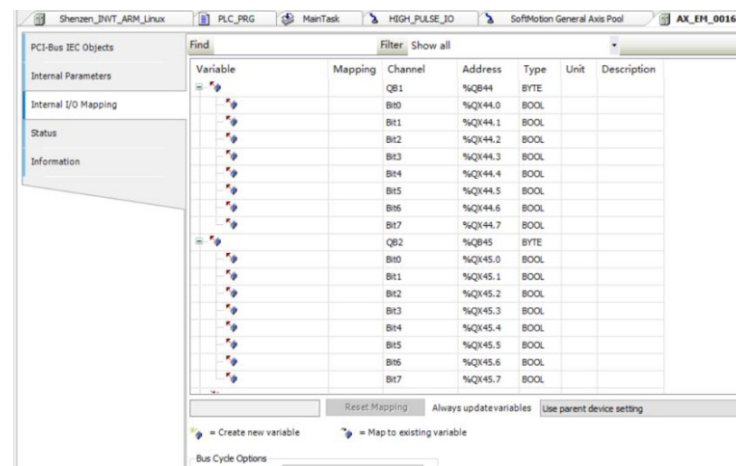

Step 4 After the compilation is successful, log in, and download and run the project. See the following figure.

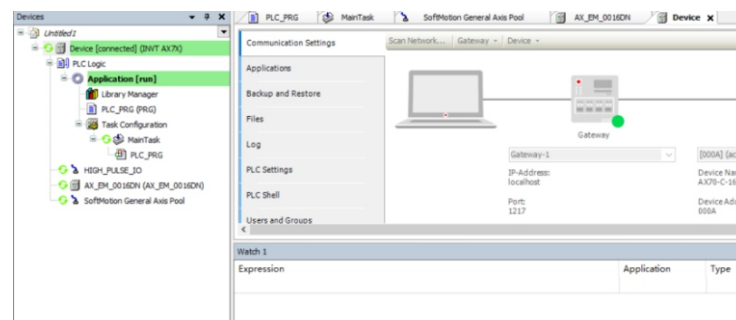

7 Pre-startup check and preventive maintenance

7.1 Pre-startup check

If you have completed the wiring, ensure the following before starting the module to work:

1. The module output cables meet requirements.
2. The expansion interfaces at any levels are reliably connected.
3. The application programs use the correct operation methods and parameter settings.

7.2 Preventive maintenance

Perform preventive maintenance as follows:

1. Clean the programmable controller regularly, prevent foreign matters falling into the controller, and ensure good ventilation and heat dissipation conditions for the controller.
2. Formulate maintenance instructions and regularly test the controller.
3. Regularly check the wiring and terminals to ensure that they are securely fastened.

8 Further information

Please feel free to contact us for further information. Please provide the product model and serial number when making an inquiry.

To obtain related product or service information, you can:

- Contact INVT local office.
- Visit www.invt.com.
- Scan the following QR code.



Customer Service Center, Shenzhen INVT Electric Co., Ltd.

Address: INVT Guangming Technology Building, Songbai Road, Matian, Guangming District, Shenzhen, China

Copyright © INVT. All rights reserved. Manual information may be subject to change without prior notice.

